

## JCL-304 / JCL-319 Gas Conditioning Systems



### APPLICATION

- For extractive gas analysis
- For emission and process monitoring
- Continuous sample gas conditioning of humid process gases
- Continuous drying of sample gas to a precise low and constant outlet dew point
- Minimises water vapour cross sensitivities and volumetric errors

### BENEFITS

- Complete solution for a great number of applications
- Longterm reliable reproducible measuring results
- Optimum operational safety due to self-monitoring
- Extremely precise long term stable dew point even under varying loads
- Fast response time due to low dead volume
- Very low dissolution rates
- Continuous condensate removal
- Low maintenance operation
- Easy to maintain design

### FEATURES

- For wall or 19"-rack mounting
- Individual configuration due to modular design
- Basic device with high-performance compressor sample gas cooler
- 1 to 4 independent sample gas paths
- Integrated condensate pumps
- Speed controlled fan
- 11 status-LED's with event memory
- 2 status contacts
- Additional options:
  - High performance corrosion resistant sample gas pump
  - Easy to maintain robust fine dust filter
  - Corrosion resistant flowmeter with precise needle valve
  - Reliable condensate monitoring
  - Acid dosing pump
  - RS 485 interface



# JCT

Analysentechnik  
GmbH

Gas Sampling Probes

Heated Sample Lines

Sample Gas Coolers

Condensate  
Treatment

Accessories

Gas Conditioning  
Systems

Sample Gas  
Converters

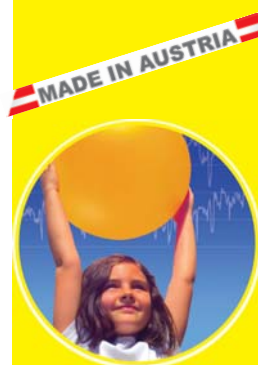

## TECHNICAL DATA

Model	JCL-304	JCL-319
Description	Sample gas conditioning system	
Cooling principle	compressor cooling with hot gas bypass	
Number of gas paths	1 - 4	
<b>Operation</b>		
Flow rate*	max. 120 NI/hr	
Gas temperature inlet*	max. +140°C	
Dew point inlet*	max. +80°C	
Dew point outlet	+3°C	
Dew point stability (for constant inlet conditions)	±0,1K	
Ambient temperature	+5...+45°C	
Operating pressure	0,2...2,2 bara	
Ready for operation	< 10 min	
Pressure drop at max. flow rate	2 mbar	
<b>Construction</b>		
Dimensions over all ( B x H x T )	440 x 300 x 408 mm	483 x 310 x 408 mm
Installation	stand alone or wall mounting	19"-rack mounting
Mounting position	horizontal	
Weight	25...31 kg (dependant on configuration)	
Housing, colour	sheet steel 1,5 mm, powder coated, RAL 1016 S, front alu nature	
Material heat exchanger	PVDF	
Dead volume per gas path	48 ml	
Connection sample gas / condensate outlet	PVDF hose fitting DN 4/6 mm	
Approvals / signs	CE	
<b>Electrics</b>		
Power supply	220....240 VAC 50/60 Hz or 100....115 VAC 50/60 Hz	
Power consumption (depending on load, ambient temperature and configuration)	200...345 VA	
Connection power / status signal /sample gas pump	3 x connector EN175301-803 form A / B with PG 9 - panduit, 3/4pole	
Fusing	external on installation site, fuse characteristic C: 230 VAC 6 A; 115 VAC 10 A	
Protection class	IP 20 (EN 60529)	
On - time	100 %	
Alarm set points	<0 / >+10°C	
Status relay	volt free changeover contact	
Gas sample pump relay	volt free contact NC	
Switching capacity relays	max. 250 VAC / 8 A (1,5 A at 250 VDC); min. 5 VADC 5 mA	
Data interface (option)	DB 9 female	
Interface protocol (option)	RS 485 / ST Bus	
Bus cable length max.	1000 m	

\* Results from the effective cooling capacity at 25°C ambient temperature and 3°C outlet dew point and can be influenced by further operational parameters

\*\* With internal sample gas pump use pump relay for release of this internal pump

## DIMENSIONS

### JCL-304

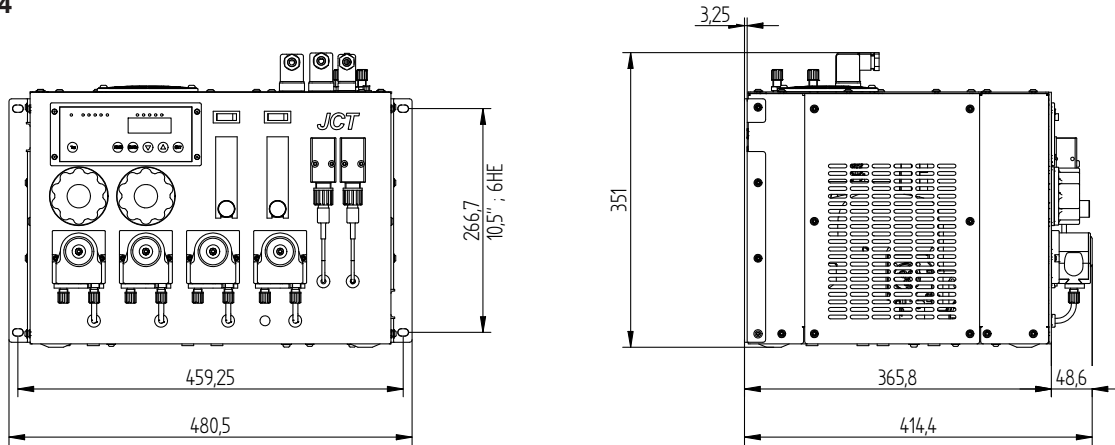

### JCL-319

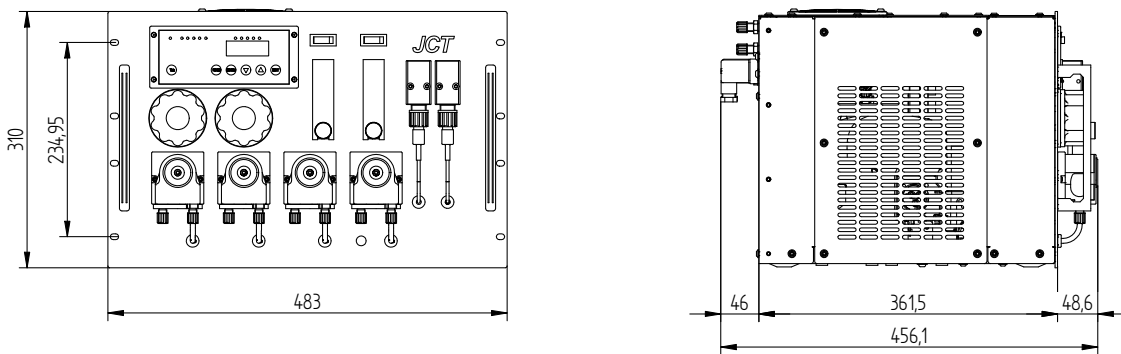

Dimensions in mm

## APPLICATION EXAMPLES / GAS FLOW DIAGRAMS

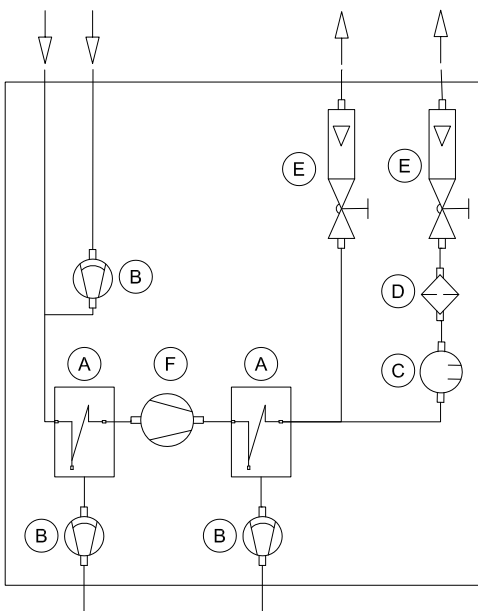

Part No. JCL-304.22611210  
Part No. JCL-319.22611210

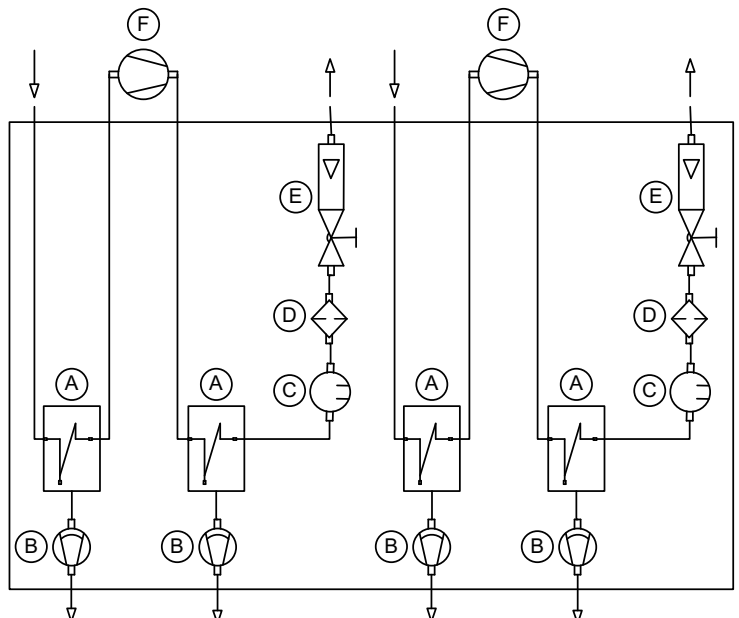

Part No. JCL-304.24422200  
Part No. JCL-319.24422200

A	Gas heat exchanger
B	Condensate pump / dosing pump
C	Condensate sensor

D	Fine dust filter
E	Flow meter with needle valve
F	Sample gas pump (external not included, suitable sample gas pumps are to be found in chapter 5)

# ORDER CODES

## JCL-304 and JCL-319

Housing	Stand alone / wall mounting	304.											
	19"-Rack mounting	319.											
Power supply	115 VAC 50/60 Hz											1	
	230 VAC 50/60 Hz											2	
Gas heat exchangers	1 Gas heat exchanger	A										1	
	2 Gas heat exchangers	A										2	
	3 Gas heat exchangers	A										3	
	4 Gas heat exchangers	A										4	
Condensate pumps	1 Condensate pump JSR-25	B										1	
	2 Condensate pumps JSR-25	B										2	
	3 Condensate pumps JSR-25	B										3	
	4 Condensate pumps JSR-25	B										4	
	1 Dosing pump JSR-25 + 1 Condensate pump JSR-25	B										5	
	1 Dosing pump JSR-25 + 2 Condensate pumps JSR-25	B										6	
	1 Dosing pump JSR-25 + 3 Condensate pumps JSR-25	B										7	
Fine dust filter	Without fine dust filter	D										0	
	1 Fine dust filter JF-1 incl. PTFE filter element	D										1	
	2 Fine dust filter JF-1 incl. PTFE filter element	D										2	
Condensate detectors	Without condensate detector	C										0	
	1 Condensate detector KW-2 with 1 sensor	C										1	
	1 Condensate detector KW-2 with 2 sensors	C										2	
Flowmeter with needle valve	Without flowmeter	E										0	
	1 Flowmeter 10....100 NI/hr	E										1	
	2 Flowmeter 10....100 NI/hr	E										2	
Sample gas pump	Without sample gas pump											0	
	1 Sample gas pump JSP-86											1	
Option	Without additional options											0	
	JCT VISU-System, software, remote control, RS485 interface											1	
Order code		JCL-											

Some possible combinations of options are technically futile and therefore not available. Please ask the JCT sales team for advice.

## JCT Analysenteknik GmbH

Werner Heisenberg-Straße 4 A-2700 Wiener Neustadt  
 Tel. +43 (0) 2622 / 87201 Fax +43 (0) 2622 / 872011  
 E-Mail: [sales@jct.at](mailto:sales@jct.at) Web: [www.jct.at](http://www.jct.at)

